

## SURVEILLANCE SYSTEM

**Yatendra Bhargava, Dheeraj Bhargava**

Dept of Computer Science, Department of Mechanical Engineering

Maharishi Arvind Institute of Engineering & Technology, Jaipur

Swami Keshwanand Institute of Technology, Jaipur, Rajasthan

bhargavadheeraj04@gmail.com

### *Abstract*

*Disturbed by the gruesome terror attacks in the country, including the one at “Taj Hotel” in Mumbai forced us to develop a product which enforces to capture the terrorist and ensures civilian’s safety without having any use of ammunition, arms or any life loss.*

*The system works with sensors attached on window panes of a building where surveillance is to be made. These sensors are then connected to a heating element and CCTV cameras. When the sensors are activated from a distance with a laser beam, the heating element spew chemicals on the terrorists to make them unconscious and the cameras start automatically.*

### **I. INTRODUCTION**

In this dramatic and corporate world security has been an essential thing in the present day scenario. So for the security reason from terrorist and other groups we are developing a project which enforces to capture the terrorist and the civilian’s safe without having any use of ammunition or any arms.

Let’s have an example of attack on “Hotel Taj”, at that time Indian Defense team was in fail condition that how to locate the position of terrorist and capture them. So to conclude over this problem we had developed this gadget which helps the Defense team to locate the position of terrorist and make them capture by switching on the security camera and blow some vaporized chemical which makes them unconscious and then after terrorist can be easily captured.

### **II. COMPONENTS AND PROCESS**

A device when activated by a laser beam from a distance as far as half-a-kilometer can take control over CCTV cameras and spew chemicals on the terrorists to make them unconscious. The system works with sensors attached on windowpanes of a building where surveillance is to be made. These sensors are then connected to a heating element and CCTV cameras. When the sensors are activated from a distance with a laser beam, the heating element and the cameras start automatically. "The sensors have IR-Diode element,

which detects laser beams, and timer IC-555 which produces oscillation and acts as an electronic switch to start the heating element and camera. The system runs on 12 volt battery which can operate 7-8 cameras".

**Block diagram**

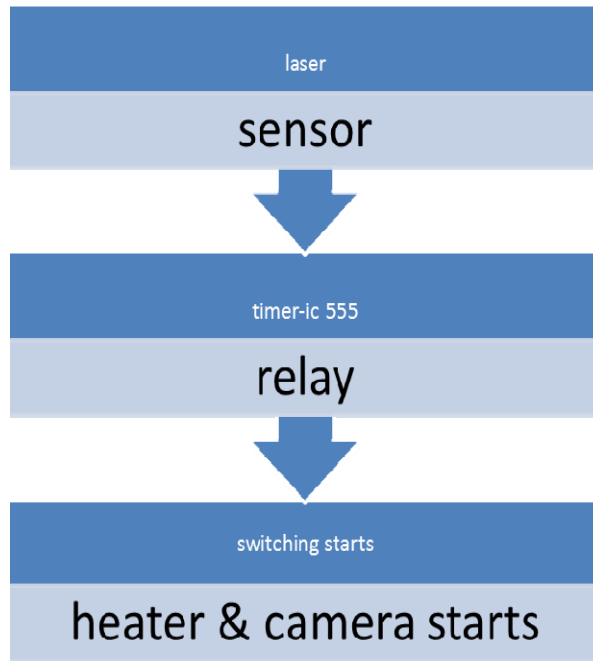

**Circuit diagram**

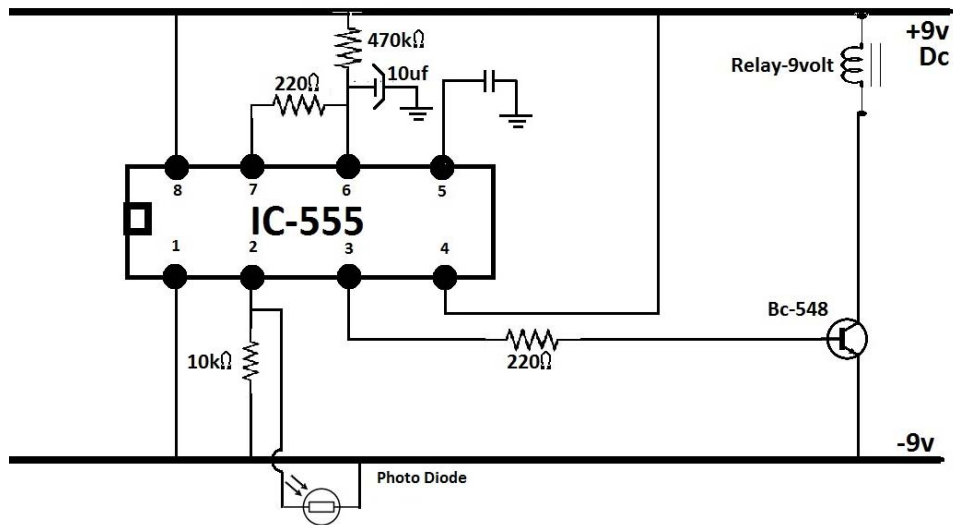

**Components used:**

- i. Timer ic-555
- ii. Resistances(220E,10k,47k,220k,1M)
- iii. Transistors(Bc-548,Bc-558)
- iv. Capacitors(10Mf,220Mf)
- v. Relays(9 volts)
- vi. Transformer(12 volt)
- vii. Dc-motor
- viii. Electrolytic L.E.D
- ix. Light depending resistance
- x. Speaker
- xi. Diodes
- xii. Regulator ic-7808

Besides it, we try to save human efforts. Here in this paper we introduce that **gadget** which fulfills the requirement by completing the job without having any physical appearance of human at that place. This gadget mainly plays an important role at the place where we need to operate any electronic device having no personal appearance there. It means that we can operate it from any corner of this world. It is applicable for both urban and rural areas.

- Farmers feel indolent to irrigate their fields at the time of hazy morning during winters. They have to go 2-3 km's apart from their house to the field to switch on their main power of water motor.

Here the problem can be easily sort out using this **gadget**. The switch of water motor can be easily operated being distance apart of it by just making a call to the place where we have to just make the irrigation start.

**III. HOW THIS GAGET WORKS:**

Here we use electro-magnetic wave theory with a combination of wireless technology (i.e. cell-phone) on a platform of timer ic-555.

When the electro-magnetic waves radiated from cell phone given to an electrolytic L.E.D then, L.E.D lights up & activate the oscillator circuit with the help of light depending resistance which in result works as a kind of switching transmitter.

The whole apparatus makes the user independent of manual working to do any of the work except doing a call to the target where a cell phone is placed. When this cell phone rings or vibrates it radiates electro-magnetic waves. Here no need of any person to attend a call. The cell phone works in any of the mode (i.e. silent, vibrate or ringing).

The above gadget is just attached to the appliance which a person needs to operate.

#### IV. CURRENT STATUS & PROPOSED

We had developed our prototype and it has been showcased at different national exhibitions and gets exposure through media.

This technological project has following features:

- **Cost effective:** This gadget includes cheap components which reduces its price to 300/- only
- **User friendly:** Nowadays mobile phone has a good approach to every human so any person can operate this gadget easily without having pre-training for this.
- **Upgradable:** This gadget generally operates only one of the device at a time, but it can be Upgraded to operate multi-device with the help of DTMF (Dual Tone Multiple Frequency) technique.
- **Portable:** The components used in this gadget are small in size. Hence makes the gadget Portable.
- **Practical use:** The gadget has a wide application in rural and urban area. It can be used in Agriculture, offices, laboratories, homes.
- **Industrial production:** small and cheap components are imposed in this gadget which can be readily available for its production.

**Proposed Budget:** The gadget 2 can be made with a little amount of 300/- only, which is an easy approach to everyone. A cell phone is also required for this purpose mainly the cheap models of nokia-3310, nokia-2626, and nokia-1650.

The gadget 1 costs 1500/- only. Hence the whole surveillance system cost will be 1800/- only.

## V. CONCLUSION

Security concerns have risen to alarming levels as terrorism and unseen dangers lurking around cause huge damage to human life and intellectual property. To safeguard these hi-tech attacks and intrusions we need equally sophisticated security device and can make our society secured.

## REFERENCES

1. [www.scribd.com/.../Block-Diagram-of-IC-Timer-Such-as-555-and-Its-working](http://www.scribd.com/.../Block-Diagram-of-IC-Timer-Such-as-555-and-Its-working)
2. [www.microwaves101.com/encyclopedia/absorbingradar1.cfm](http://www.microwaves101.com/encyclopedia/absorbingradar1.cfm)
3. William Stallings, '*Wireless Communications and Networks*'